

---

He Yuan<sup>1</sup>, Li Qinglian<sup>2</sup>

1

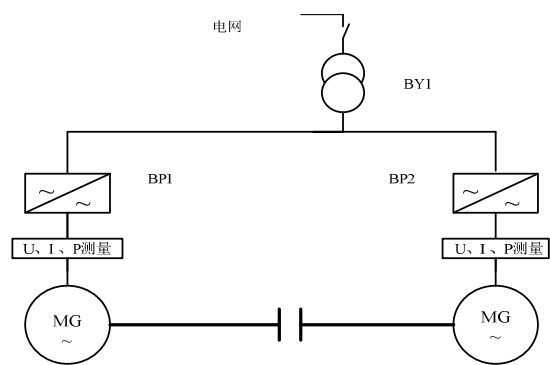

c

GB1032-2005

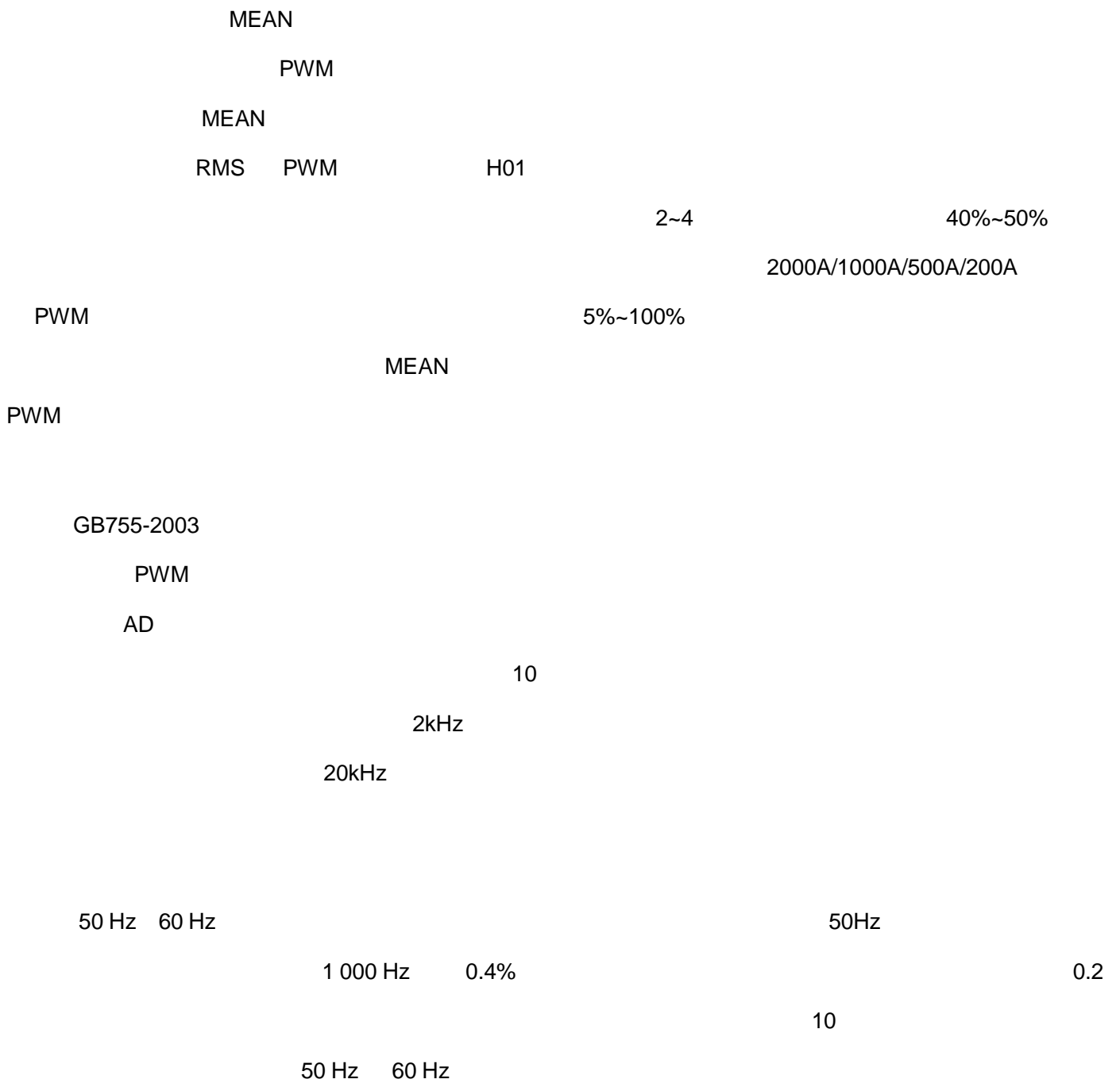

				0.7%+	0.3%	
					PWM	
			500Hz			
	8.5Hz	5.1.3			1833.4A	
		3.4Hz				
			10.50A			1.5
	YOKOWAGA		2750.1A			
WT3000					262	
0.1Hz		WT3000				3000A
			10A	7		
1			3000A/1000A/500A/200A/100A/50A/20A			
	PLL					
	10Hz~2600Hz			Denfysik		
	PLL	3000		50ppm		5ppm
		0.1Hz~66Hz	10V	3000A	10A	
2	IEC		3.333mV			
		45Hz~66Hz				
3						
		10Hz~2600Hz.				
			PLL			
3000						
		3.4Hz				
	10.2ksps					
	5.1kHz	500Hz	5.5kHz			
	500Hz					

---